



P.O. Box 22326  
Lincoln, NE 68542

PF: 402/421-9464 | WEBSITE: [www.sitescapesonline.com](http://www.sitescapesonline.com)  
FX: 402/421-9479 | E-MAIL: [info@sitescapesonline.com](mailto:info@sitescapesonline.com)

TITLE *WYNNE*  
*TABLE & BENCHES*

PRODUCT NO.  
*WN6-5462*

INCH TOLERANCES U.O.S.  
FRACTION--  $\pm 1/16"$   
ANG-----  $\pm 1^\circ$

THE INFORMATION CONTAINED IN THIS DRAWING IS THE SOLE PROPERTY OF SITESCAPES, INC. ANY REPRODUCTION IN PART OR AS A WHOLE WITHOUT THE WRITTEN PERMISSION OF SITESCAPES, INC. IS PROHIBITED.

\*Available in powder coat and DuraCoat finishes

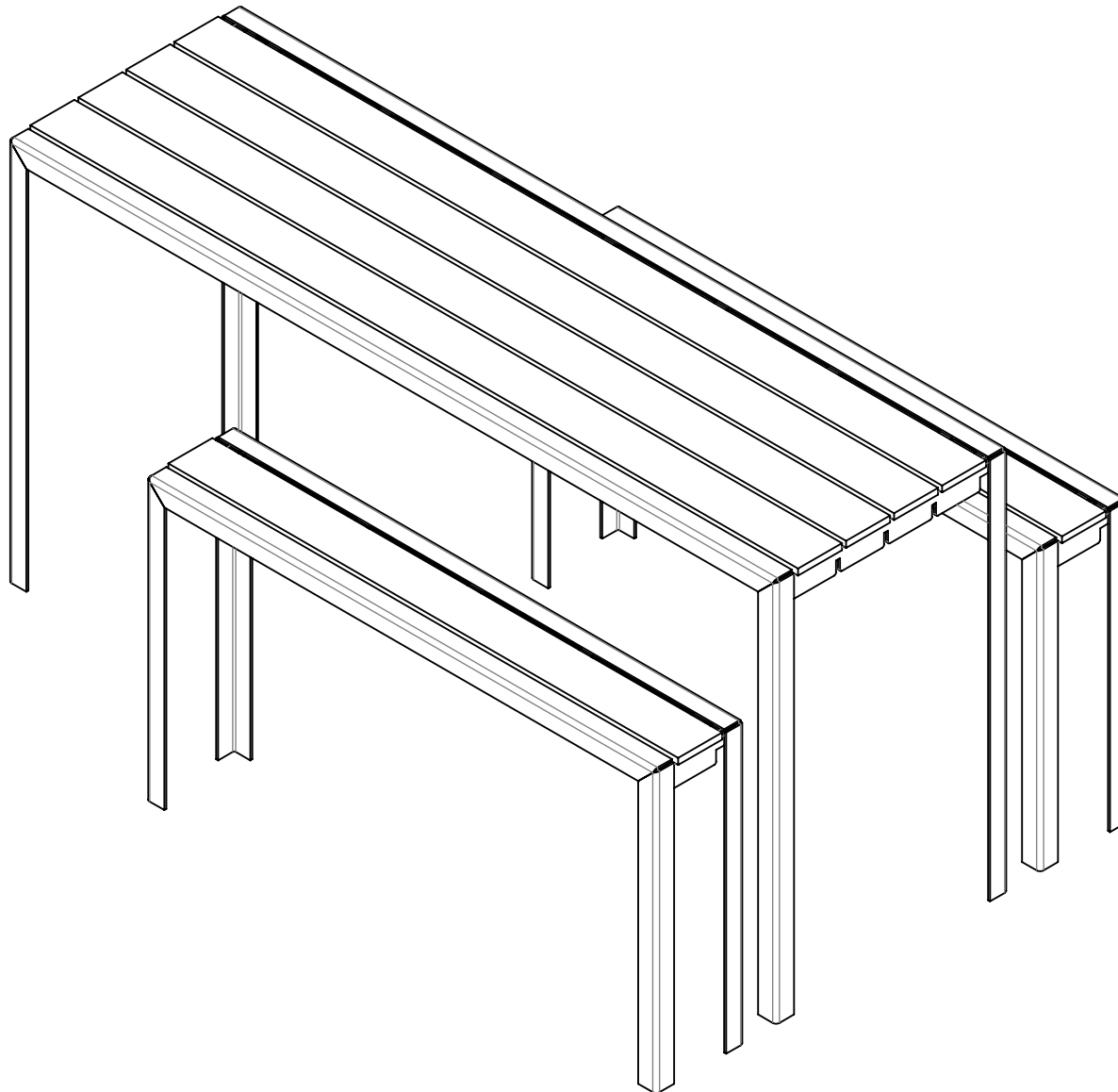



P.O. Box 22326  
Lincoln, NE 68542

PF: 402/421-9464 | WEBSITE: [www.sitescapesonline.com](http://www.sitescapesonline.com)  
FX: 402/421-9479 | E-MAIL: [info@sitescapesonline.com](mailto:info@sitescapesonline.com)

INCH TOLERANCES U.O.S.

FRACTION--  $\pm 1/16"$   
ANG-----  $\pm 1^\circ$

THE INFORMATION CONTAINED IN THIS DRAWING IS THE SOLE PROPERTY OF SITESCAPES, INC. ANY REPRODUCTION IN PART OR AS A WHOLE WITHOUT THE WRITTEN PERMISSION OF SITESCAPES, INC. IS PROHIBITED.

TITLE *WYNNE  
TABLE & BENCHES*

PRODUCT NO.  
*WN6-5462*

\*Available in powder coat and DuraCoat finishes

MATERIALS LIST:

Table:

- (1) Table Top Slats - 1" x 6" Nominal Ipe Wood
- (2) Frame - 2 1/4" x 1/4" Formed Steel Angle
- (3) Support Plates - 1/4" Steel Plate

Bench:

- (4) Bench Slats - 1" x 6" Nominal Ipe Wood
- (5) Frame - 2 1/4" x 1/4" Formed Steel Angle
- (6) Support Plates - 1/4" Steel Plate

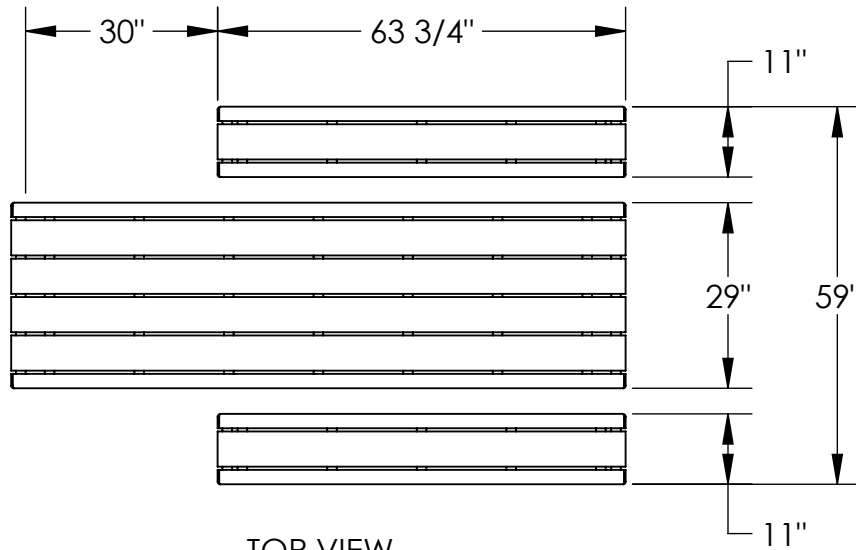

TOP VIEW

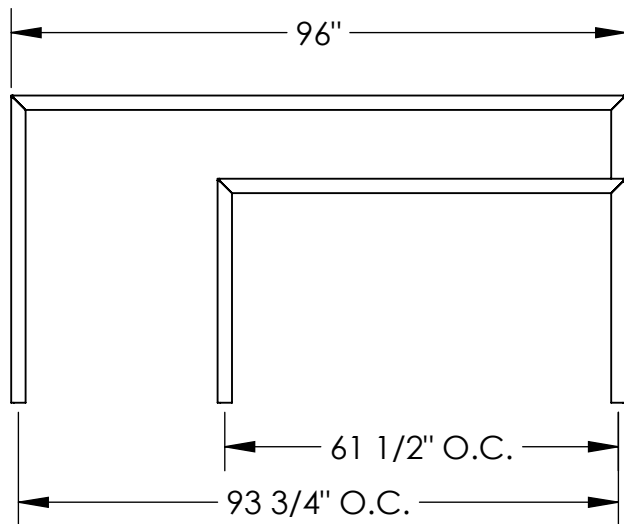

FRONT VIEW

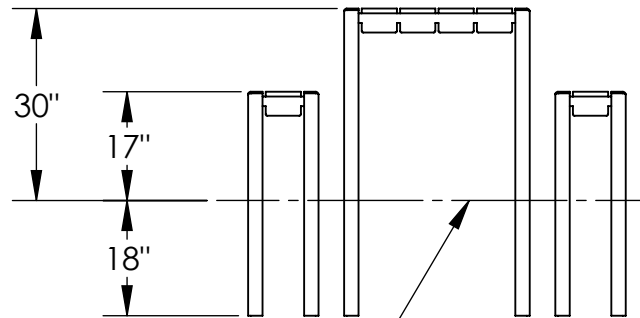

SURFACE GRADE

RIGHT SIDE VIEW

